

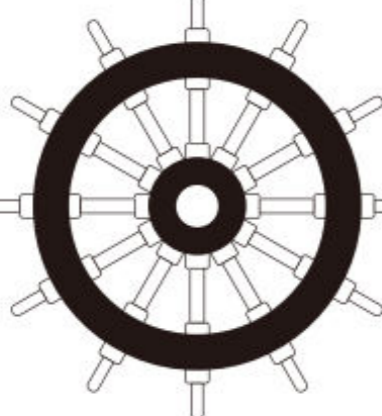

Catalogue

SCBA series

Self-Contained Breathing Apparatus



SS-BA-9L

- External Air Source
- External Air Source Alarm
- High-pressure Fast-fill
- Digital Pressure Gauge
- Head-up Display (Distress)
- Communication Mask
- Second-user rescue

Features:

- ▶ The Swivel back-plate frame provides a comfortable and adjustable($\pm 30^\circ$) fit with a lower profile
- ▶ Better designed shoulder straps to disperse and reduce the user burden, also with ease of donning and doffing
- ▶ Equipped with sFP or cFP facepiece, plus pressure demand regulator with First
- ▶ Breath Activation and low exhalation resistance for easy breathing and reduced user fatigue
- ▶ Fluorescent gauge and whistle end-of-service alarm be combined into one assembly for the ease of use

Components	Specifications
Full Face Mask	Silicon
Back Plate Assembly	Aramid fiber harness (Nomex is available)
Cylinder Valve	90°C self-lock w/guage w/hand wheel
Air Cylinder	6.8L Composite (9.0L Composite is available)
Alarm volume	> 90 dBA
Working Pressure	$\cong 300\text{Bar}$
Alarm activation	55 \pm 5Bar
Weight(without air cylinder)	5.05KG
Exhalation Resistance	$\cong 1000\text{Pa}$
Inhalation Resistance	$\cong 500\text{Pa}$
Approved temperature	-30°C to +60°C
Nominal Duration	45-60minutes
Approvals	MED 96/98/EC/ EN137: 2006 / EN 136:1998+AC:2003

As the advanced air breathing apparatus be applied to firefighting, rescue, oil/gas industry etc., for the complex performance. Which is bedesigned with durability and dependability and available for the multiple accessories to offer an appropriate product for the actual needs. HYSTEC incorporated end-user feedback in every step of the design process to deliver to the fire service the next platform of SCBA.



1 SET / CASE / CARTON

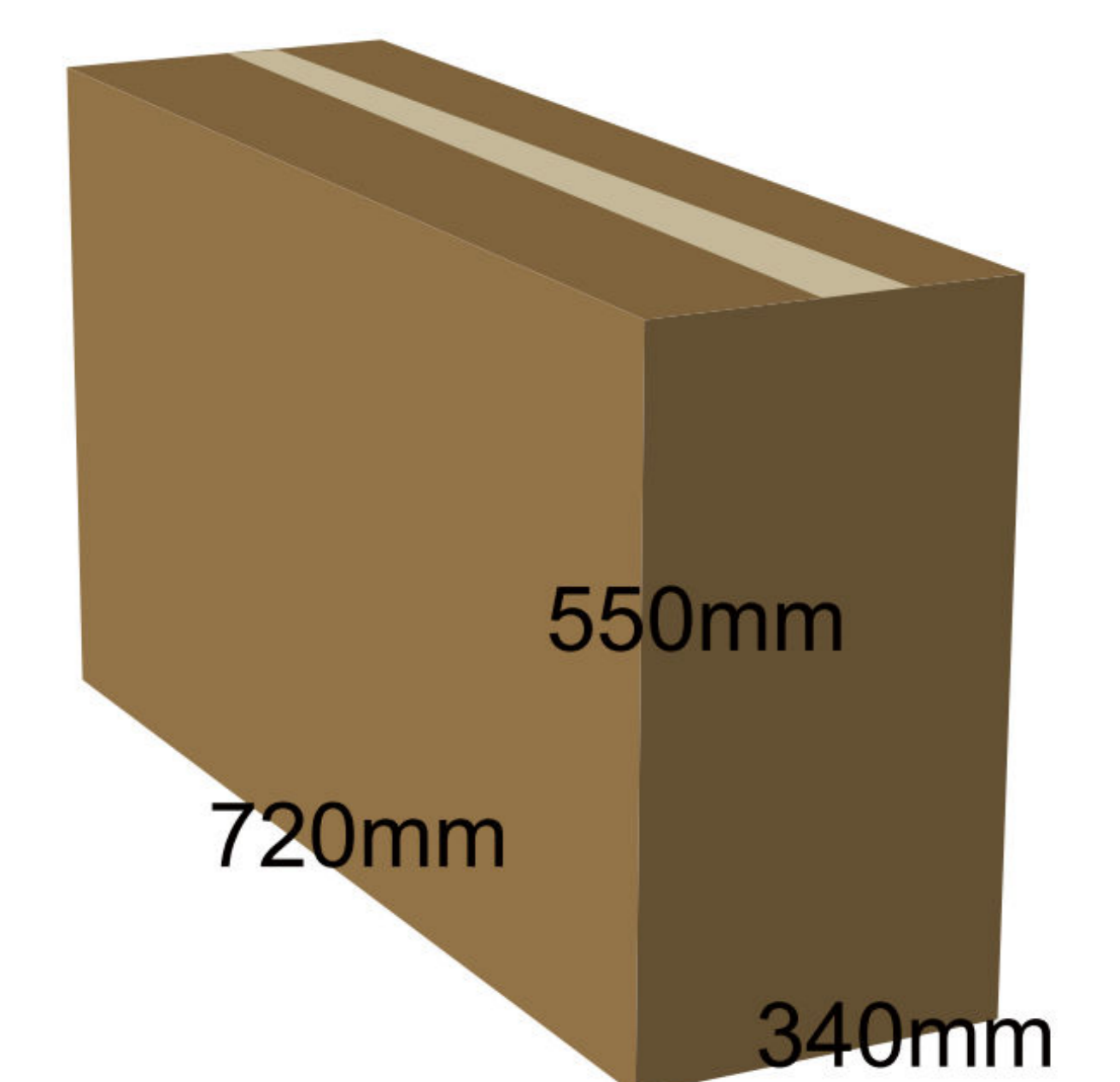
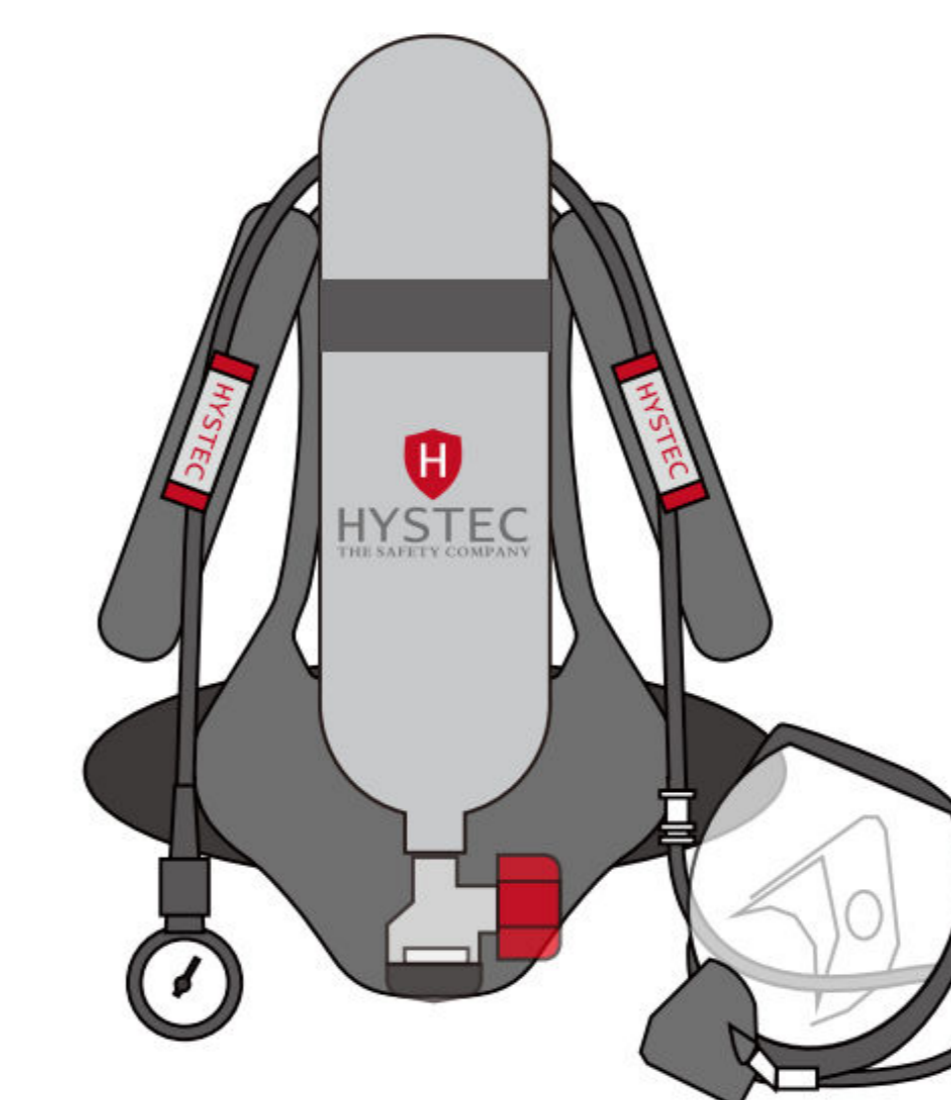

Standard & Code





Catalogue

SCBA series

Self-Contained Breathing Apparatus

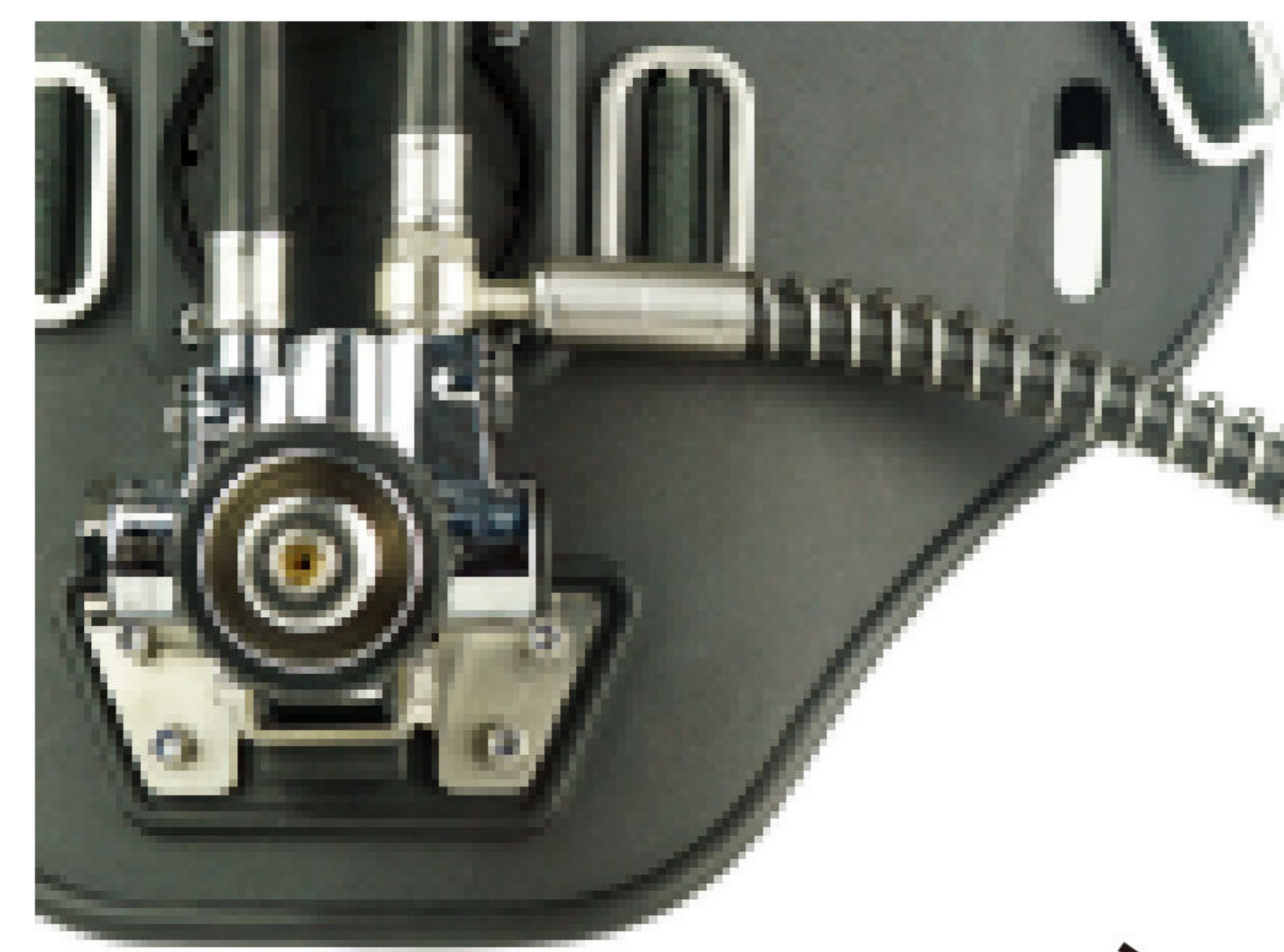

HY-JYQ-02

HY-QP-06



SS-BA-9L

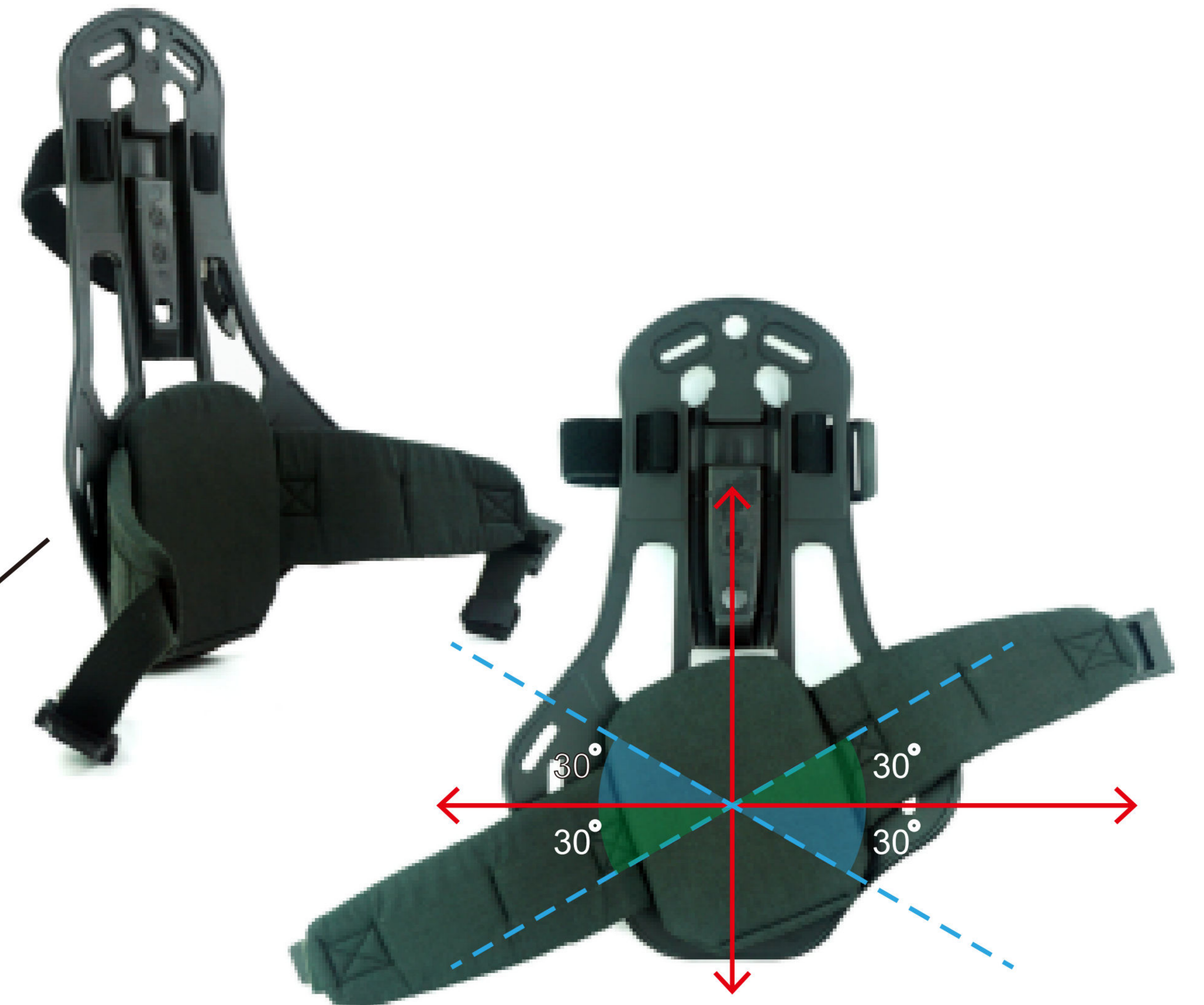

HY-BB-05



HY-PF-03



HY-MZ-03

Air Breathing Apparatus Complete set in a Box
Communication mask with HUD unit and D-LDV
Backplate assembly with regulator/T-cock/Electrical
gauge-w/inside alarm/High-pressure quick charge
Self-lock cylinder valve 90 degree with pressure gauge
and handwheel
Without box 11 kg



Address : Ta' Gidwet Street, Marasclala - Malta
Opening hours: Monday to Saturday 09:00 - 19:00
Telephone : +(356) 2163 3164
Mobile : +(356) 7969 7709 / +(356) 9944 3426
Email : info@salpasub.com
Website : www.salpasub.com